



WINTER – 2022 EXAMINATION

Subject Name: ENGINEERING DRAWING





Model Answer

Subject Code:

22207

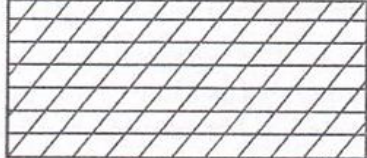
Important Instructions to examiners:

- 1) The answers should be examined by key words and not as word-to-word as given in the model answer scheme.
- 2) The model answer and the answer written by candidate may vary but the examiner may try to assess the understanding level of the candidate.
- 3) The language errors such as grammatical, spelling errors should not be given more Importance (Not applicable for subject English and Communication Skills).
- 4) While assessing figures, examiner may give credit for principal components indicated in the figure. The figures drawn by candidate and model answer may vary. The examiner may give credit for any equivalent figure drawn.
- 5) Credits may be given step wise for numerical problems. In some cases, the assumed constant values may vary and there may be some difference in the candidate's answers and model answer.
- 6) In case of some questions credit may be given by judgement on part of examiner of relevant answer based on candidate's understanding.
- 7) For programming language papers, credit may be given to any other program based on equivalent concept.
- 8) As per the policy decision of Maharashtra State Government, teaching in English/Marathi and Bilingual (English + Marathi) medium is introduced at first year of AICTE diploma Programme from academic year 2021-2022. Hence if the students in first year (first and second semesters) write answers in Marathi or bilingual language (English +Marathi), the Examiner shall consider the same and assess the answer based on matching of concepts with model answer.

Q. No.	Sub Q. No.	Answer	Marking Scheme
01	a	<p>Solve any five 10 Marks</p> <p>Draw the conventional representation of following materials :</p> <p>Wood  rubber </p>	01 mark for each type
	b	<p>Double v Butt Welded joint  </p> <p>Single J Butt Welded joint  </p>	01 mark for each type



WINTER – 2022 EXAMINATION

Subject Name: ENGINEERING DRAWING

Model Answer

Subject Code:

22207

Q. No.	Sub Q. N.	Answer	Marking Scheme
1	c	<p>Cross sections of V- Belt and V- Belt Pulley</p> <p>Cross-Section of V-Belt</p> <p>V-Belt Pulley</p>	01 mark for each type
	d	<p>Rag foundation Bolt</p> <p>Rag foundation Bolt</p>	02 marks
	e	<p>Muff- Coupling</p> <p>Muff- Coupling</p>	02 marks



WINTER – 2022 EXAMINATION

Subject Name: ENGINEERING DRAWING

Model Answer

Subject Code:

22207

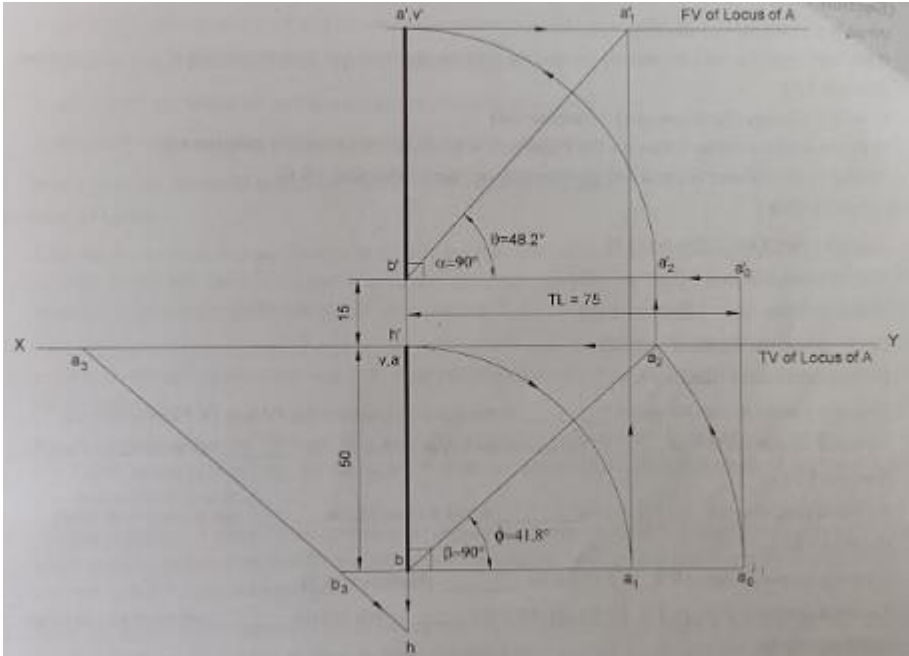
Q. No.	Sub Q. N.	Answer	Marking Scheme
1	f g	<p>i) It may be Elliptical, Parabolic or Hyperbolic</p> <p>ii) It may be Elliptical, Parabolic or Hyperbolic</p> <p>i) Define Tetrahedron:-</p> <p>The simplest tetrahedron is made of four equal-sided triangles: one is used as the base, and the other three are fitted to it and each other to make a pyramid.</p> <p>ii) Define Frustum of a cone:</p> <p>When a cone is cut by a cutting plane parallel to its base, the remaining portion thus obtained after removing the top portion is called the Frustum of a cone.</p>	<p>01 mark for each</p> <p>01 mark for each</p>
2	a		<p>02 Marks for initial position</p> <p>02 Marks for Final position</p>



WINTER – 2022 EXAMINATION

Subject Name: ENGINEERING DRAWING

Model Answer

22207

Q. No.	Sub Q. N.	Answer	Marking Scheme
2	b		<p>02 Marks for initial position</p> <p>02 Marks for Final position</p>
	c		<p>02 Marks for initial position</p> <p>02 Marks for Final position</p>



WINTER – 2022 EXAMINATION

Subject Name: ENGINEERING DRAWING

Model Answer

Subject Code:

22207

Q. No.	Sub Q. N.	Answer	Marking Scheme
2	d		<p>02 Marks for initial position</p> <p>02 Marks for Final position</p>
	e		<p>02 Marks for initial position</p> <p>02 Marks for Final position</p>



WINTER – 2022 EXAMINATION

Subject Name: ENGINEERING DRAWING

Model Answer

Subject Code: 22207

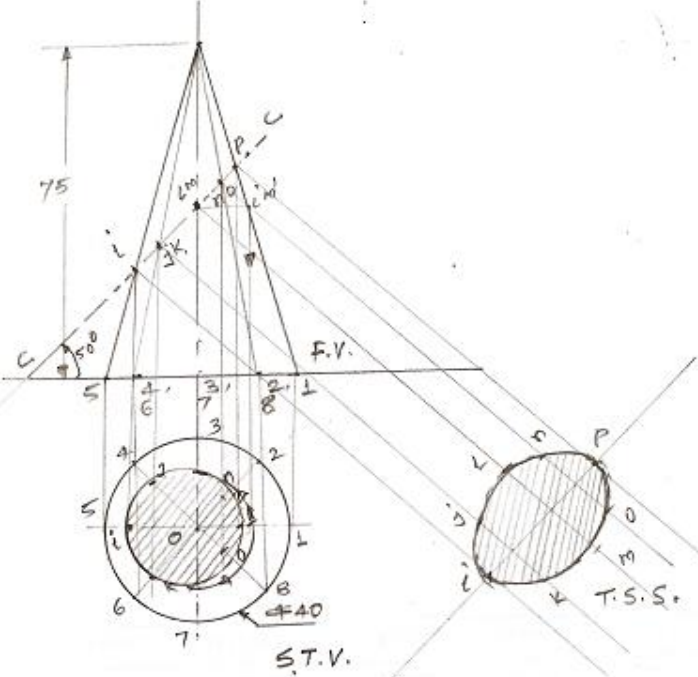
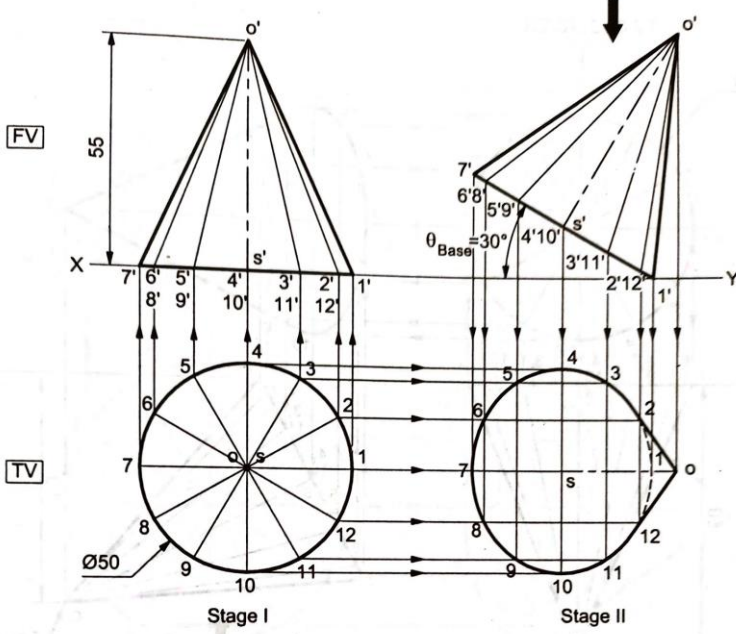
Q. No.	Sub Q. N.	Answer	Marking Scheme
03	a		F.V. 02Marks S.T.V. 04Marks T.S.S. 02Marks
	b		Initial View 04Marks Final View 04Marks



WINTER – 2022 EXAMINATION

Subject Name: ENGINEERING DRAWING

Model Answer

Subject Code: 22207

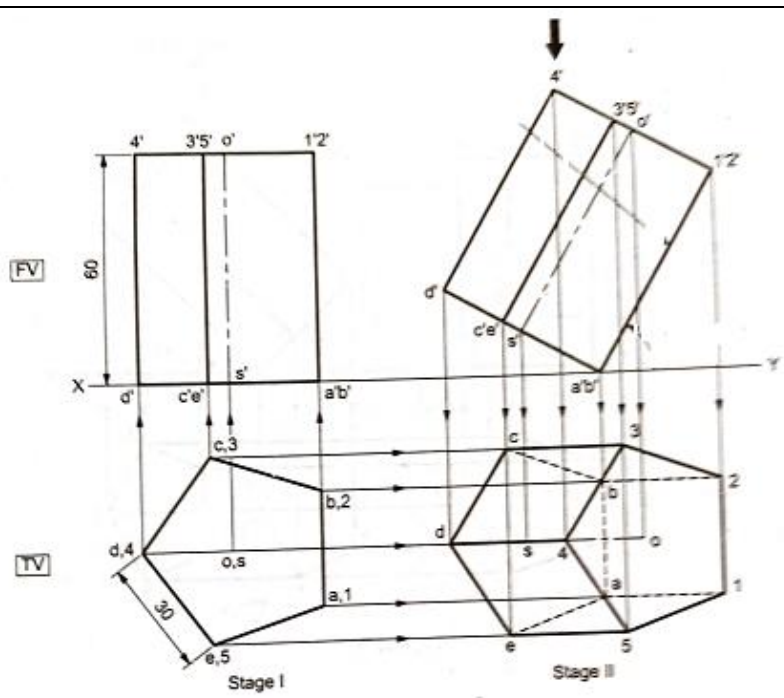
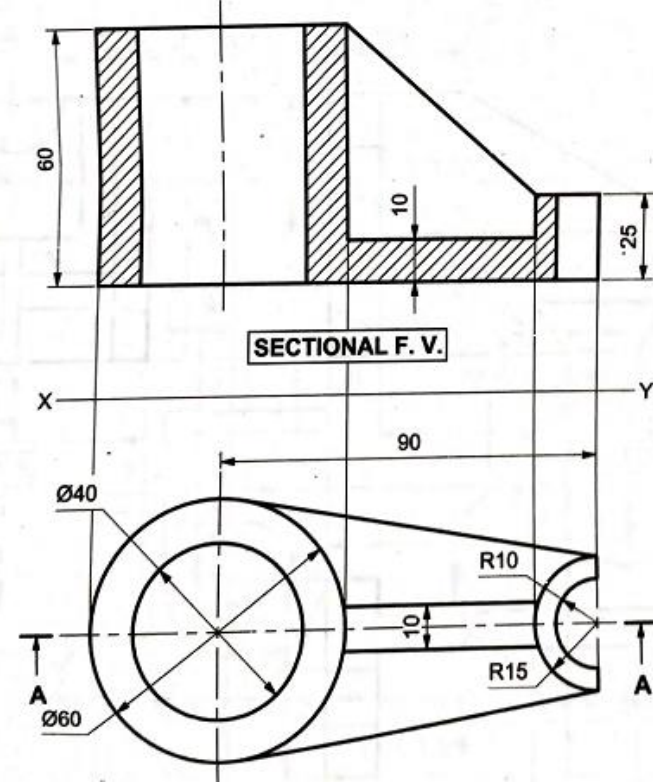
Q. No	Sub Q.N	Answer	Marking Scheme
3	c		Initial View 04Marks Final View 04Marks
4	a		S.F.V. 04Marks T.V. 04Marks



WINTER – 2022 EXAMINATION

Subject Name: ENGINEERING DRAWING

Model Answer

Subject Code:

22207

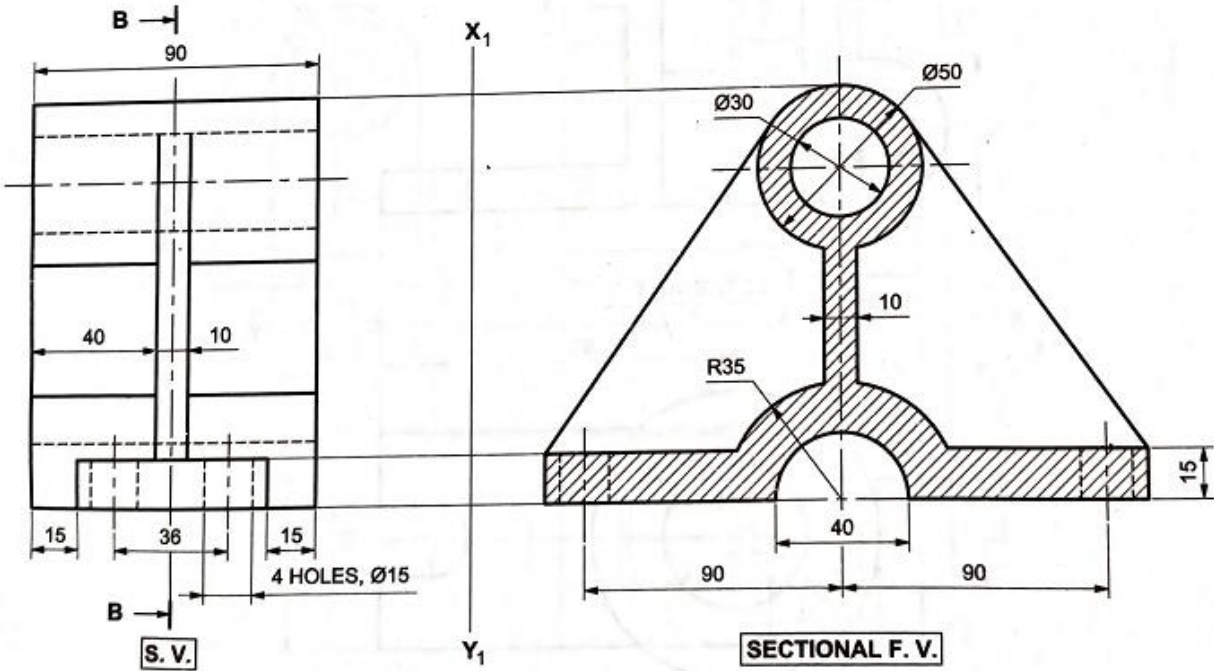
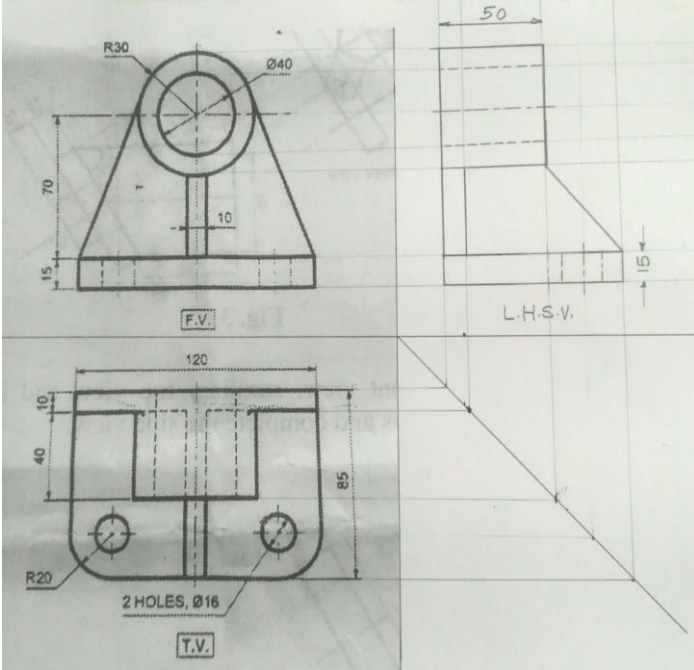
Q. No.	Sub Q. N.	Answer	Marking Scheme
4	b		S.F.V. 04Marks R.H.S.V. 04Marks
4	c		F.V. 02Marks T.V. 02Marks Missing View. 04Marks



WINTER – 2022 EXAMINATION

Subject Name: ENGINEERING DRAWING

Model Answer

Subject Code:

22207

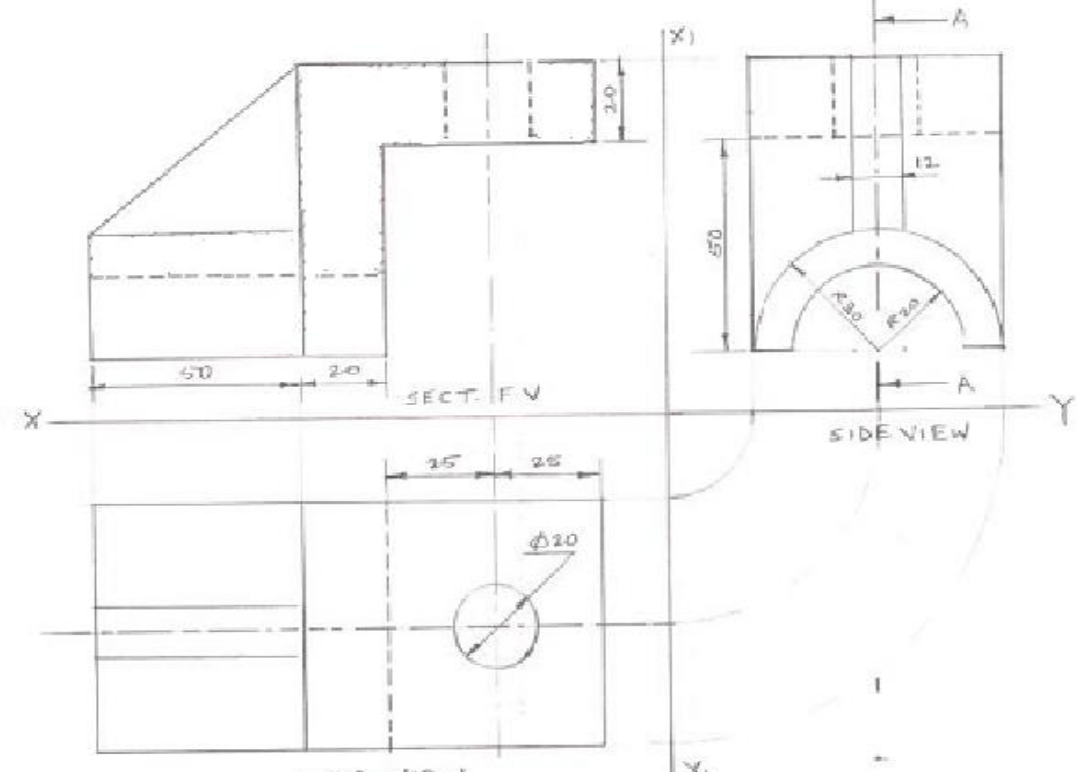
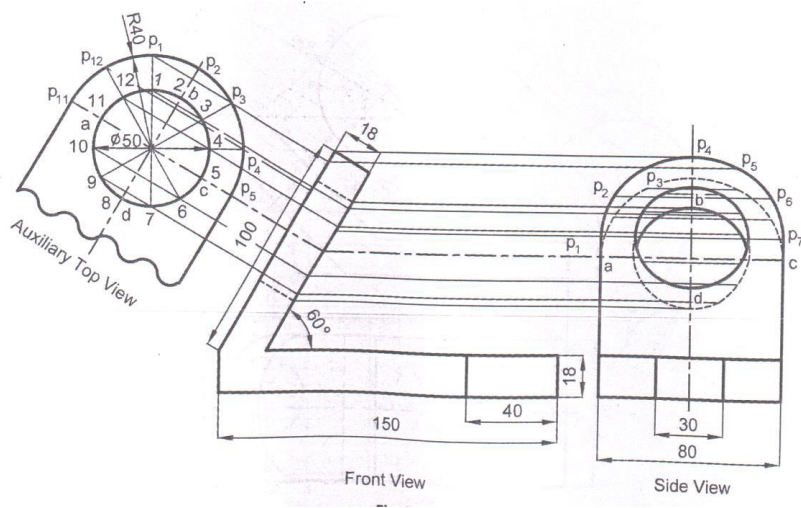
Q. No.	Sub Q. N.	Answer	Marking Scheme
05	a		F. V. 02Marks Side view 02Marks T.V 04Marks
	b		02 Marks for F.V., Auxiliary T.V. 02 Marks and 04 Marks for L.H.S.V.



WINTER – 2022 EXAMINATION

Subject Name: ENGINEERING DRAWING

Model Answer

Subject Code:

22207

Q. No.	Sub Q. N.	Answer	Marking Scheme
05	c	<p>R.S. VIEW</p> <p>FRONT VIEW</p>	02 Marks for F.V., Auxiliary and T.V. 02 Marks and 04 Marks for R.S.V.